

Alfa Laval SaniMidget SB UltraPure

Rotary Spray Head

Introduction

The Alfa Laval SaniMidget SB UltraPure is a rotary spray head tank cleaning machine for hygienic environments. Designed to clean tanks from 1 - 15 m³.

The Alfa Laval SaniMidget SB UltraPure minimizes the consumption of water and cleaning media. Easy to customize to meet customer requirements, the SaniMidget SB UltraPure allows companies to spend less time cleaning and more time producing.

The polymer of the SaniMidget SB UltraPure is approved and tested according to USP class VI.

Alfa Laval UltraPure equipment is designed and configured to meet the high demands of the biotech and pharmaceutical industry. Special attention is given to documentation, material and surface finish, in compliance with current Good Manufacturing Practices (cGMP) and other guidance for this industry.

The SaniMidget SB 3-A UltraPure is authorized to carry the 3-A symbol.

Application

The Alfa Laval SaniMidget SB UltraPure is engineered for the removal of residues from hygienic tanks across the biotech and pharmaceutical industries.

Benefits

- 40% faster cleaning = more time for production
- Saves up to 40% of your cleaning cost
- Dynamic cleaning performance and 360° full wetting
- Easy to retrofit traditional spray balls to a more economical solution

Standard design

Different choice of spray patterns suitable for various applications and tank designs, ranging from simple tanks to more complex tanks with structures such as agitator and baffles. The SaniMidget SB UltraPure is lubricated by the cleaning media.

Working principle

The flow of the cleaning media causes the head of the Alfa Laval SaniMidget SB UltraPure to rotate, and the fan-shaped jets layout a swirling pattern throughout the tank or reactor. This generates the wetting/impact needed for the efficient



removal of the residual product; the cascading flow covers all internal surfaces of the vessel.

Spray Pattern

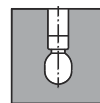

360°

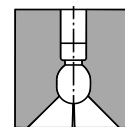

270° up

Certificates

Q-doc, Q-doc incl. FAT/SAT, 3A and ATEX.



TECHNICAL DATA

Lubricant:	Lubrication by rinse/cleaning fluid
Wetting radius:	Max. 3 m
Impact cleaning radius:	Max. effective 1.4 m

PHYSICAL DATA

Materials

Metallic parts:	AISI 316L (UNS S31603)
Non-metallic parts:	PEEK MG
Surface finish:	Ra < 0.8 µm

Temperature

Max. working temperature:	95 °C
Max. ambient temperature:	150 °C

Weight:	1": 0.20 kg
---------	-------------

Connections

- Weld-on: 1" ISO 2037, or DN25 DIN11850-R1, or 1" BPE US
- Clip-on: 1 1/2" ISO 2037, or 1" or 1 1/2" BPE US

Clip-on options

Easy-on/off clip (Ø4.0 mm). (Clip needed for both clip-on and weld-on versions to assemble the machine).

Caution

Avoid hydraulic shock, hard and abrasive particles in the cleaning liquid, as this can cause increased wear and/or damage of internal mechanisms. In general, a filter in the supply line is recommended. Do not use for gas evacuation or air dispersion. For steaming we refer to the manual.

Qualification Documentation

Documentation specification

	Equipment Documentation includes:
Q-doc	<ul style="list-style-type: none">• EN 1935/2004 DoC• EN 10204 type 3.1 inspection Certificate and DoC• FDA DoC• GMP EC 2023/2006 DoC• EU 10/2011 DoC• ADI DoC• QC DoC
ATEX	ATEX approved machine for use in explosive atmospheres. Category 1 for installation in zone 0/20 in accordance with Directive 2014/34/EU II 1G Ex h IIB 85 °C ...175 °C Ga II 1D Ex h IIIC T85 °C ...T140 °C Da
Q-doc + FAT-SAT	Qualification Documentation includes: <ul style="list-style-type: none">• Q-doc• RS, Requirement Specification• DS, Design Specification incl. Traceability Matrix• FAT, Factory Acceptance Test incl. IQ and OQ• SAT, Site Acceptance Test protocol incl. IQ and OQ for End-User Execution

Flow Rate

m³/h

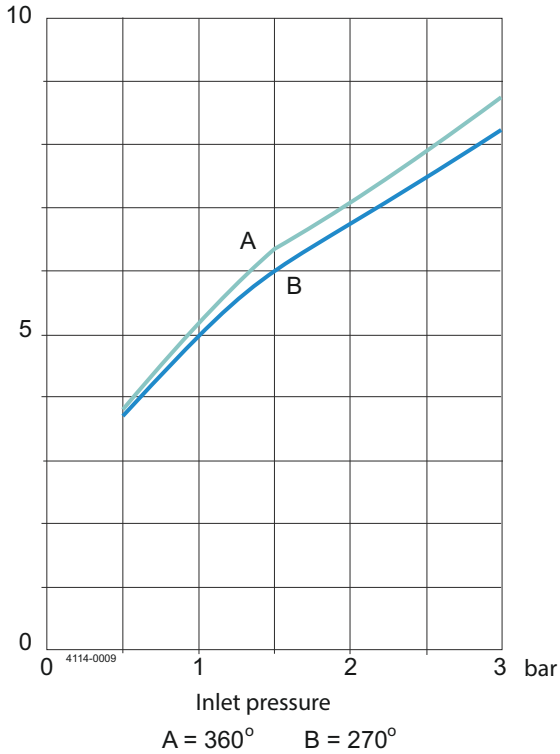

Cleaning radius

Flow length (radius) [m]

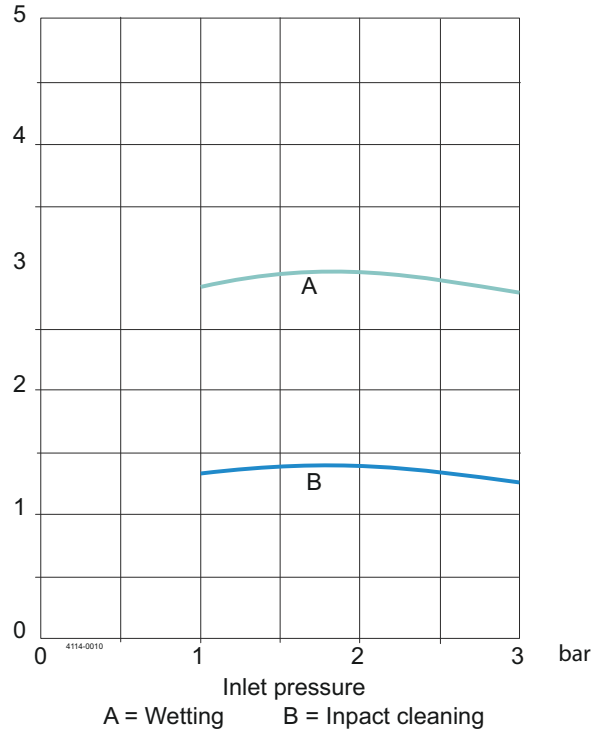

For Clip-on models, the flow rate is increased by approx. 0.5 m³/h.

Note: The inlet pressure has been taken immediately before the inlet to the machine. In order to achieve the performance indicated on the curves, the pressure drop in the supply lines between pump and machine must be taken in consideration and the water temperature during testing was approx. 20 °C.

Dimensions (mm)

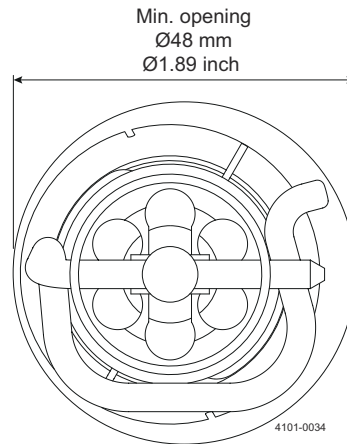
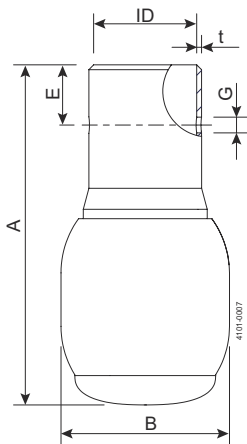

	Clip-on 1" BPE US		Weld-on 1" ISO 2037		Weld-on 1" BPE US		Weld-on DN25 DIN R1	
	mm		mm		mm		mm	
ID	Ø25.7		Ø22.6		Ø22.1		Ø25.7	
t	1.2		1.2		1.65		1.2	
B	Ø42.0		Ø42.0		Ø42.0		Ø42.0	
A	84.8		104.8		108.8		84.8	
Ø-clip	Ø4.0		Ø4.0		Ø4.0		Ø4.0	
G	Ø4.1		Ø4.1		Ø4.1		Ø4.1	
E	15.0							

This document and its contents are subject to copyrights and other intellectual property rights owned by Alfa Laval AB (publ) or any of its affiliates (jointly "Alfa Laval"). No part of this document may be copied, re-produced or transmitted in any form or by any means, or for any purpose, without Alfa Laval's prior express written permission. Information and services provided in this document are made as a benefit and service to the user, and no representations or warranties are made about the accuracy or suitability of this information and these services for any purpose. All rights are reserved.

200006339-2-EN-GB

© Alfa Laval AB

How to contact Alfa Laval

Up-to-date Alfa Laval contact details for all countries are always available on our website at www.alfalaval.com