



Levitated Magnetic Mixer

Alfa Laval MM UltraPure, Magnetic Mixer

Application

Alfa Laval magnetic mixers offer effective mixing for applications with high demands on hygienic and aseptic design.

Working principle

The patented levitated bearing makes the mixer fully drainable and able to run dry. The performance ranges from low shear mixing at around 10 rpm to high intensity mixing with vortex at up to 250 rpm. Depending on the mixer task the range covers from 30 liters to 10000 liters of nominal batch size.

Standard design

The Alfa Laval MM UltraPure mixer consists of a weld plate and a mixer unit incl. gear drive. The weld plate is ordered and delivered separately to enable early preparation of the mixer installation. The mixer must be controlled by a VFD unit matched perfectly with the mixer. The VFD is pre-programmed for optimum performance.

Any brand of locally sourced VFD may be used under observation of the mixer manual



TECHNICAL DATA

Product wetted surface finish: Ra <20µ inch Mech. polish
 Option: Ra < 20µ inch and Electro polished

Working pressure: -15 to 100 PSI
 - WFI 29 to 101.5 PSI

Note: Ensure liquid is below boiling temperature

Voltage and frequency

- 3x230-460V, 60Hz

Protection class

AC motors: IP66
 AC VFD stand alone: IP66
 AC VFD enclosure unit: IP20 Nema 4X

Motor sizes

MM 338-4/6: 0.5 hp
 MM 434-8/10: 1.5 hp

Certificates

Standard delivery includes:

- 3.1 Materials Certificates, EN10204 for all product wetted parts
- USP Class VI <88> certificates for Zirconia YTZP and ISOLAST 9501
- FDA Declaration of conformity for elastomers and ceramics
- USDA-H1 conformity statement (FDA) for gear drive oil
- TSE declaration (Transmissible Spongiform Encephalopathy) / ADI declaration (Animal Derived Ingredients)
- USP Class VI <88> certificates on request for Silicon Carbide parts

PHYSICAL DATA

Materials

Impeller and Weld Plate: AISI 316L (UNS S31603)
 Drive rotor and distance piece: AISI 316L (UNS S31603)
 Motor and Gearbox: ANSI / NSF 51 compliant paint
 Male Bearing: Zirconia YTZP
 Male Bearing Gasket: ISOLAST 9501 (Perfluoro Elastomer)
 Female Bearing: Silicone Carbide
 Gearbox oil: USDA-H1

Temperature

Product mixing (10 - 250 rpm): max. 194°F
 - WFI with pressure: max. 140°F
 CIP (max 50 rpm): max. 203°F
 SIP (0 rpm): max. 302°F

Weight

MM 338: 27 lb
 MM 434: 66 lb

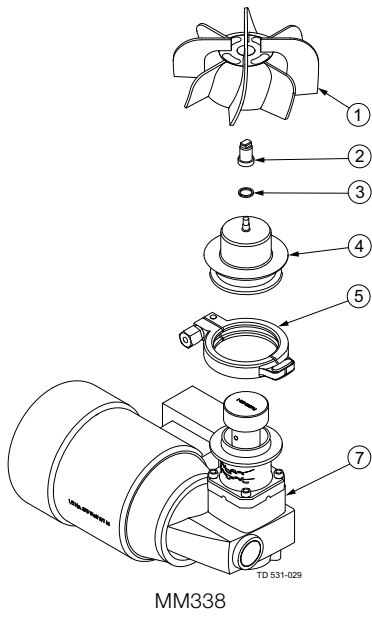

MM338

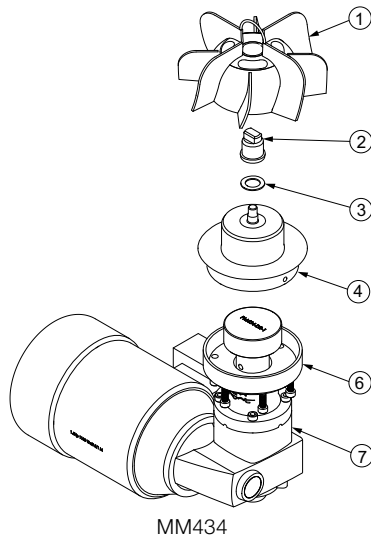

MM434

1. Impeller
2. Male bearing
3. Gasket
4. Weld plate
5. Clamp ring (only MM338)
6. Bolt connection (only MM434)
7. Drive unit

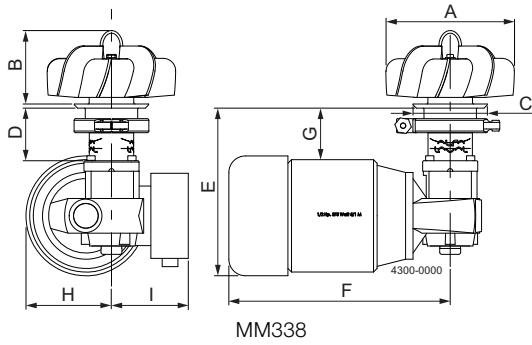

MM338

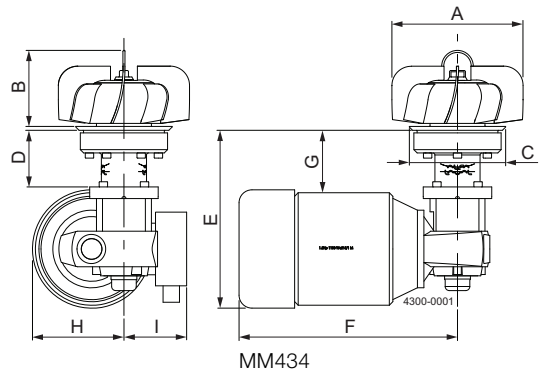

MM434

Dimensions [inch]	MM 338-4	MM 338-6	MM 434-8	MM 434-10
A	4	6	8	10
B	3.5	3.5	4.63	7.21
C	3.54	3.54	5.87	5.87
D	2.5	2.5	3.5	3.5
E	7.99	7.99	10.83	10.83
F	10.55	10.55	13.3	13.3
G	2.45	2.45	3.80	3.80
H	4.07	4.07	5.57	5.57
I	3.66	3.66	3.81	3.81

Machine Selection

Machine selection: Contact Global Technical Support, Tank Equipment

Alfa Laval reserves the right to change specifications without prior notification. ALFA LAVAL is a trademark registered and owned by Alfa Laval Corporate AB.

ESE01694ENUS 1507

© 1009 Alfa Laval

How to contact Alfa Laval
Contact details for all countries are continually updated on our website. Please visit www.alfalaval.us to access the information direct.